

Actuator

BDN60

BDN60 is a quiet and powerful actuator up to 6000N thrust, designed for use in furniture, homecare and fitness equipment. The actuator block allows a big stroke range in confined spaces. The small fitting dimensions make BDN60 an ideal solution for recliners with lifting assistance.

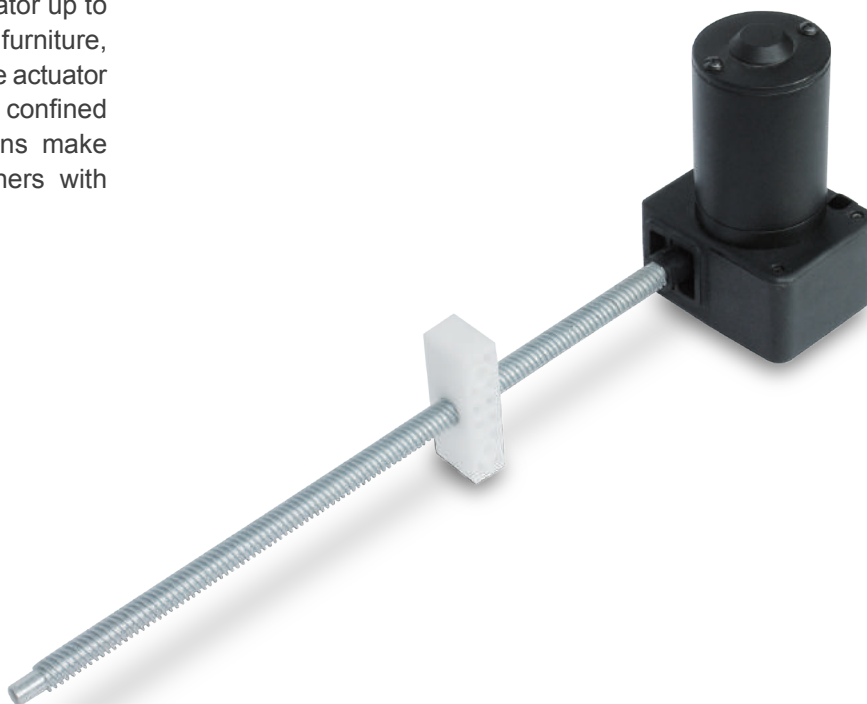

Feature

- Main applications: Furniture, homecare, and fitness equipment
- Input voltage: 24V DC / 12V DC
- Max. load: 6000N (push) / 4000N (pull)
- Max. speed at no load: 33.3 mm/sec
- Max. speed at full load: 2.9 mm/sec @ 6000N
- Stroke: 100 ~ 1000 mm
- Noise level: ≤ 53 dB
- Color: Black
- Preset limit switches
- Without outer tube
- Duty cycle: 10%, max. 2 min. continuous operation in 20 min.
- Ambient operation temperature: $-20^{\circ}\text{C} \sim +65^{\circ}\text{C}$
- Certified: CE Marking, EMC Directive 2014/30/EU

Option

- Positioning signal feedback with Hall effect sensor x 1
- Positioning signal feedback with Hall effect sensor x 2
- Mechanical brake

Compatibility

Product	Model	BDN60 spec
Control box	T control, CS1, CS2, CB3T, CB4M, CBT2	- Without positioning sensor feedback - 4-pin MOTECK F-type DIN plug
	CB3T-SY, CB4M-S, CB4M-B	- With dual Hall effect sensors - 6-pin MOTECK F-type DIN plug
Hand control	Depend on control box	- Powered by control box
	H3B, HS01, HZ01	- With MOTECK dedicated cable TL2*
	HB, H2G, HZ02, HZ03, HZ04, HZ05, HZ06	- With MOTECK dedicated cable DL1*
Accessory	Switching mode power supply: TSW1, TSW4, TSW5	- With MOTECK dedicated cable DL1 or TL2
	T Connector (Extension cable of actuator and handset, to connect to power supply or transformer box)	- 4-pin MOTECK F-type DIN plug

***Remarks:**

Dedicated cable DL1 or TL2 to connect to power supply and control directly, without control box.

Performance Data

Model No.	Push Max. (N)	Pull Max. (N)	Self-locking ability (N)	Typical Speed (mm/s)		Typical Current (A)			
				No load	Full load	No load		Full load	
						12V	24V	12V	24V
BDN60-XX-A4	6000	4000	5000	4.2	2.9	0.8	0.6	5.4	2.7
BDN60-XX-A6	4000	4000	2500	6.2	3.8	0.4	0.6	6.0	3.0
BDN60-XX-A8	3000	3000	2000	8.3	5.0	0.6	0.6	5.4	2.7
BDN60-XX-AG	1500	1500	700	16.6	12.2	0.4	0.6	5.6	2.8
BDN60-XX-KG	750	750	0	33.3	23.5	0.4	0.6	5.2	2.7
BDN60-XX-F4	5000	4000	5000	5.5	4.4	0.8	0.6	5.6	2.8
BDN60-XX-F8	3000	3000	2000	11.0	8.2	1.0	0.6	5.8	2.9

***Remarks:**

Mechanical brake is available upon request, to further enhance the self-locking ability.

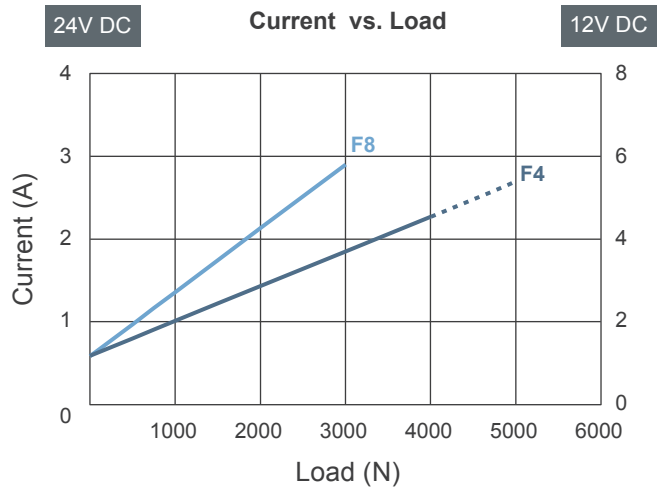
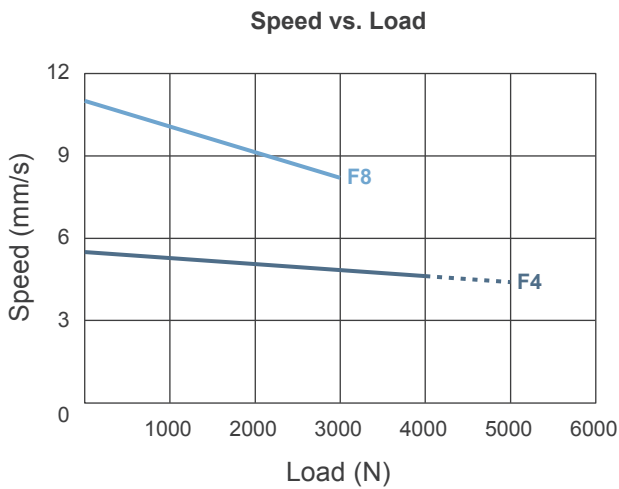
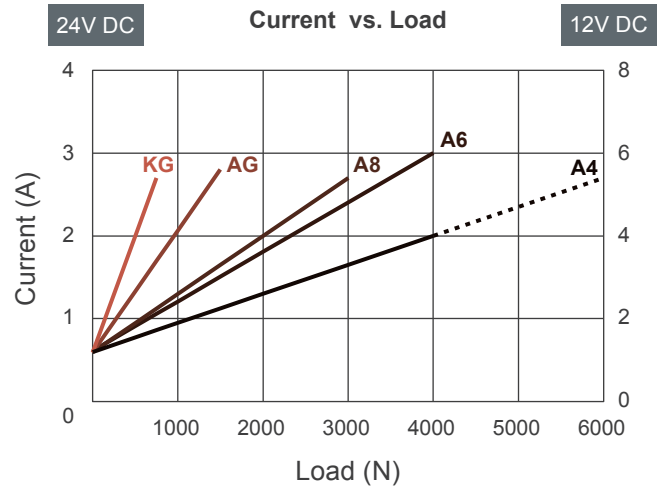
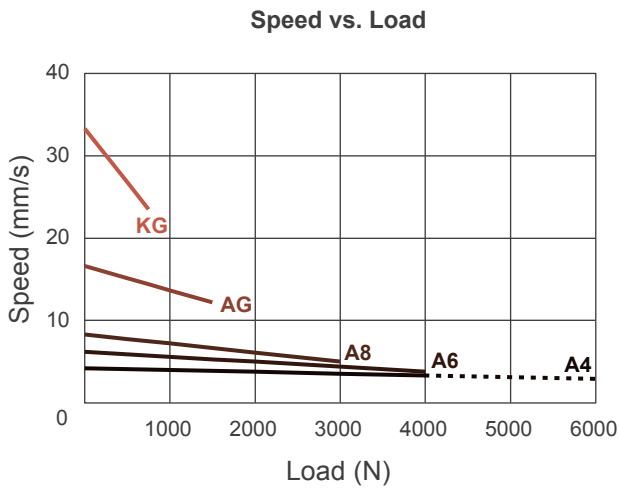

Push / Pull Load — Push Load - - -

Dimensions

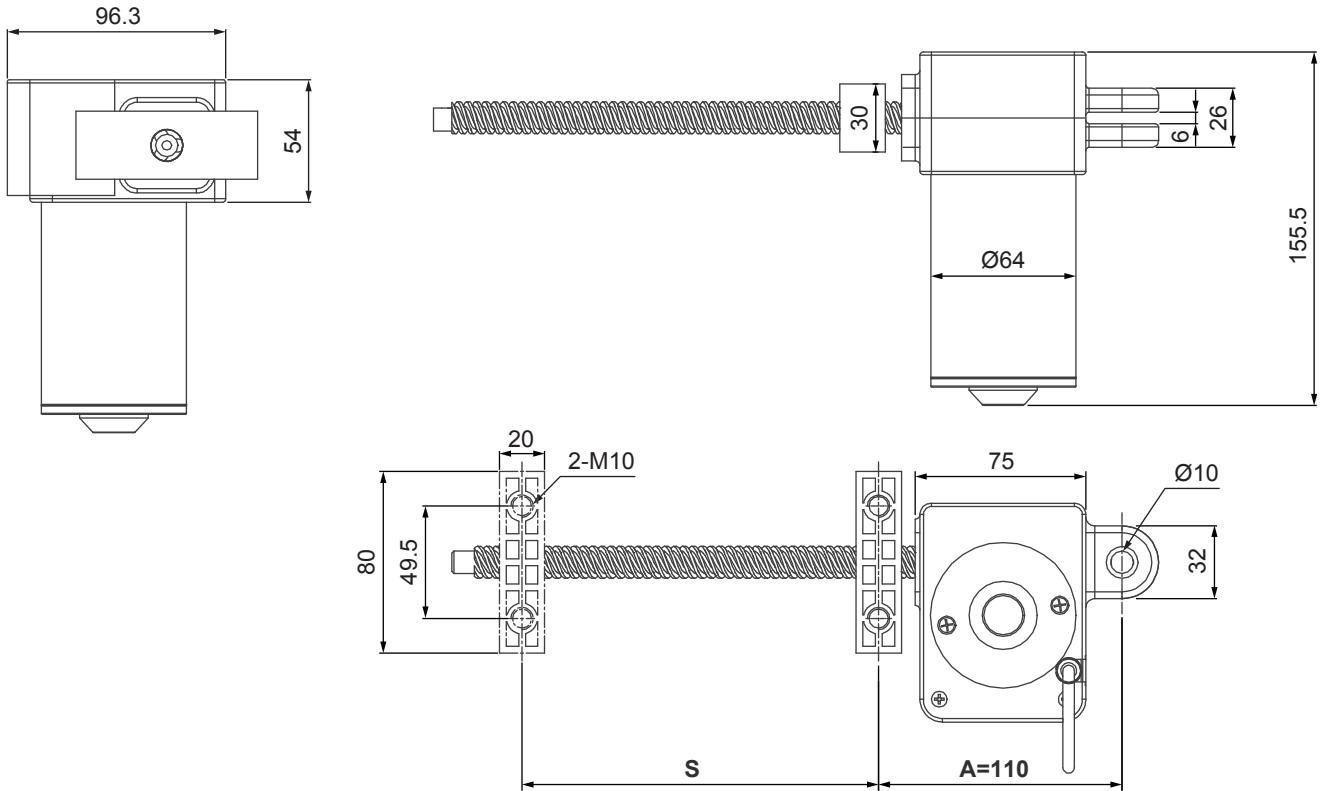

Extended length = S + A

Retracted length (A) = 110 mm Min.

Available stroke (S) range = 100 ~ 1000 mm

Please refer to following table for max. stroke of each model.

Model No.	Max. stroke (mm)
BDN60-XX- A4 -XXX.XXX-CXX	400
BDN60-XX- F4 -XXX.XXX-CXX	400
BDN60-XX- A6 -XXX.XXX-CXX	600
BDN60-XX- A8 -XXX.XXX-CXX	800
BDN60-XX- F8 -XXX.XXX-CXX	800
BDN60-XX- AG -XXX.XXX-CXX	1000
BDN60-XX- KG -XXX.XXX-CXX	1000

Front Connector

2: Plastic nut

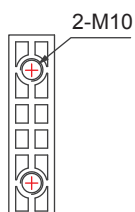

Rear Connector

1: Plastic

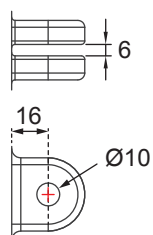

Cable Length

Dedicated cable DL1

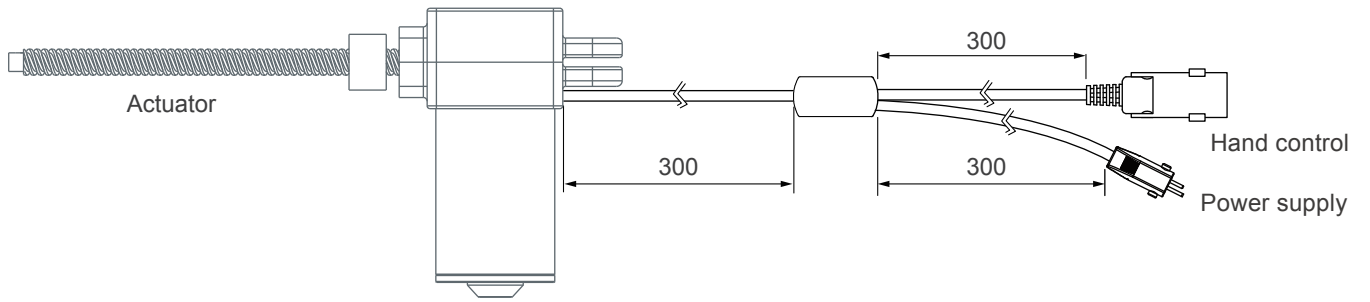

Dedicated cable TL2

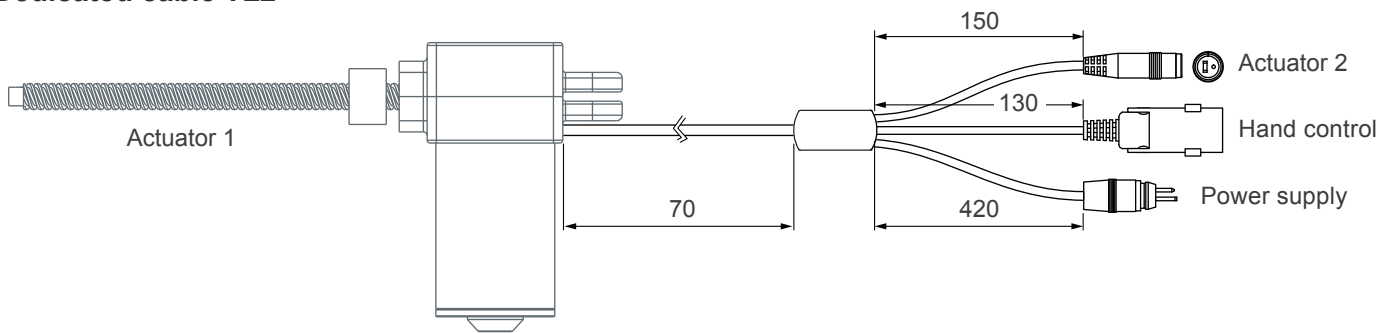

Cable Plug

> With Moteck F-type DIN plug to connect to control box

- Without positioning sensor feedback

- 1x or 2x Hall sensors for positioning

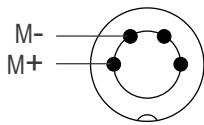

4-pin DIN plug

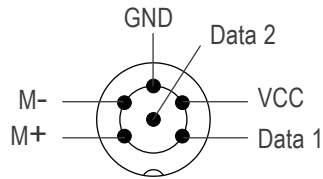

6-pin DIN plug



F-type

Note:

Connect Pin (M+) to "+" & Pin (M-) to "-" of DC power, the actuator will extend.

> Dedicated cable DL1 or TL2 to connect to hand control and power supply directly, without control box.

► Hand control connector: with Moteck U-type female connector

- 1 drive

- 2 drives

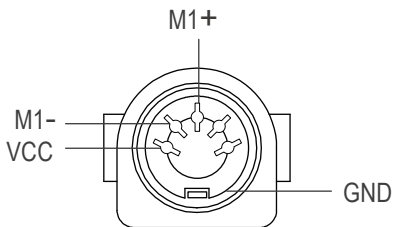

5-pin connector
(Moteck pinout: C-DIN-51H)

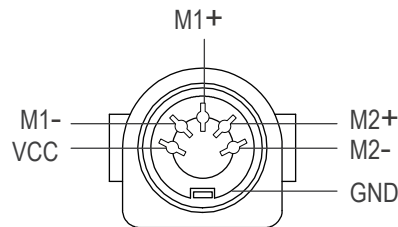

5-pin connector
(Moteck pinout: C-DIN-52H)



U-type

Note:

Connect pin (M1+) to "+" & pin (M1-) to "-" of DC power, the M1 actuator will extend. Definition of M2 actuator is the same.

► Power plug: with Moteck S-type or R-type DIN 41529 male plug

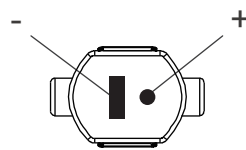

DIN 41529 plug (S-type for DL1 only)

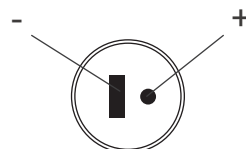

DIN 41529 plug (R-type for TL2 only)



S-type



R-type

► Connector for 2nd actuator: with Moteck R-type DIN 41529 female (for TL2 only)

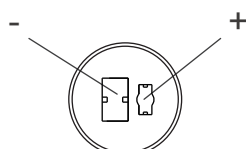

DIN 41529 connector



R-type

Ordering Key

BDN60 - 24 - A4 - 115 - 515 - C 2 1 - HS2 - BK - 1

Input voltage	12: 12V DC 24: 24V DC
Motor and Spindle type	A4 A6 A8 AG KG F4 F8 (Refer to Performance Data)
Retracted length	XXX (Refer to Dimensions)
Extended length	XXX (Refer to Dimensions)
Front connector	2: Plastic nut (Refer to Dimensions)
Rear connector	1: Plastic (Refer to Dimensions)
Positioning feedback	Blank: None HS1: Hall effect sensor x 1 HS2: Hall effect sensor x 2
Option	Blank: None BK: Mechanical brake
Cable	0: 300 mm straight 1: 1000 mm straight 2: 450 mm with 300 mm coiled A: Dedicated cable DL1, without control box (Refer to page 5) B: Dedicated cable TL2, without control box (Refer to page 5)

Terms of Use

The user is responsible for application suitability of Moteck products. As ongoing improvement process continues, products listed on the Moteck website are subject to change without prior notice. Moteck reserves the right to terminate the sales or remove any product displayed on the website, or listed in its catalogues.