

EM-348C DC-MOTOR CONTROLLER with MODBUS 12-24V, 15A and Rs-485 BUS

348cbr19 3.9.2020

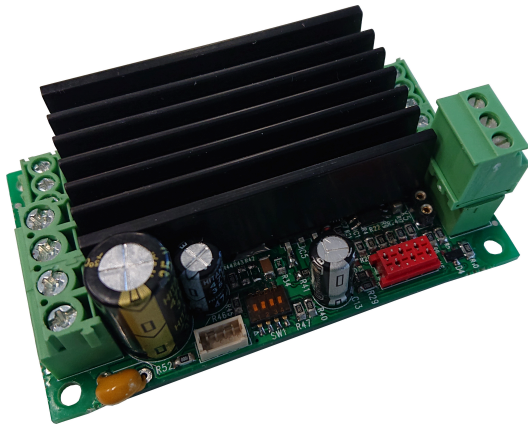

FEATURES

- Integrated Rs-485 bus
- Modbus RTU
- Parameter setting with Bus
- Control and monitor with Bus
- High current output
- Current limit
- Zero current trip
- Overvoltage brake
- Speed setting
- Magnetic brake control output
- Flexible control inputs
- Rail base mountable
- Low EMC emissions

EM-348C is a full bridge DC-motor starter. It is designed to work with DC-motor in applications where some special functions are needed. Driver has 4-quadrant full-bridge powerstage, and also brake control power output. The powerstage can be selected for use with two different frequency, the one is efficient and the other is silent. The powerstage uses smooth switching technology and has very low EMC emission. Parameter allows powerstage to be set brake or freewheel mode when stand-by.

This device is designed to control with Rs-485 Bus. The control bus use Modbus RTU protocol and with the Bus there can be set, speed, direction, acceleration and deceleration ramps and current limit. Also the monitoring and parameter setting are possible with the Bus. There is a separate instruction for operating the bus.

Device has also some local control inputs FW and BW for start the forward and backward run. STOP is for the motor shut-down but there are also available individual limit inputs for FW and BW directions. FAULT terminal has at the same time input and output function, the pin is normally low, and in fault situation it will pull up for example if overheat or current trip occurs. If FAULT-line is pulled up externally it will cause a stop and prevent the new start, so it works like Disable input. For example: if system has several units and those FAULT pins are connected together, then Fault of one card will disable other units also.

Device has two selectable control modes, continuous and impulse. In continuous mode the motor runs as long as the control is active. In impulse mode a short command starts the motor, and only a new impulse will change the status. There are also few special settings start-kick and auto reverse. The card has selectable input logics. Inputs are divided in two groups, control and limit -inputs. Groups can be individually set for NPN or PNP logic.

TECHNICAL DATA (PCB v1, prog EM-348-C v1.9)

Supply voltage cont. max. 10-35V
 Overvoltage limit adjustable 15-40V (hardware limitations)
 Start up voltage 9V, shutdown voltage 8V
 Continuous current output when ambient temp is <50°C)
 15A at 100% speed / 10A at 5-99% speed pwm=2kHz
 10A at 100% speed / 5A at 5-99% speed pwm=16kHz
 Peak (5s.) 30A at 2kHz pwm and 25A at 16kHz pwm
 Current limit adjustable 0.1-25A (at start max 30A)
 (6A version currents are typically 2.5 times smaller)
 Overheat limit 100°C
 Start and stop ramp adjustable 0-5s
 PWM frequency 2kHz / 16kHz
 Input control logic: high =4-30V, low=0-1V
 Control input impedances typ. 47kohm
 Limit/pulse input (pin 2 and 3) impeded. typ 10kohm
 Control input response time typ 5ms.
 Fault out. PNP open coll. max. 50mA
 Brake out NPN open coll max. 35V / 2A
 min. brake res. at 12V 6.8 ohm / 24V 15ohm
 Disable in active $U_{in} > 1V$ (NPN)
 Bus Rs-485, two wire half duplex, 9600kb/s
 Motor and supply connectors 2.5mm
 Control connectors 1mm
 Dimensions 42x72x height 25mm (6A version 18mm)
 Dimensions in DIN-rail base 45x80x45mm
 CE-tested for industrial environment (emc)
 Operating temp (T_a) -40...60°C
 Weight 75g

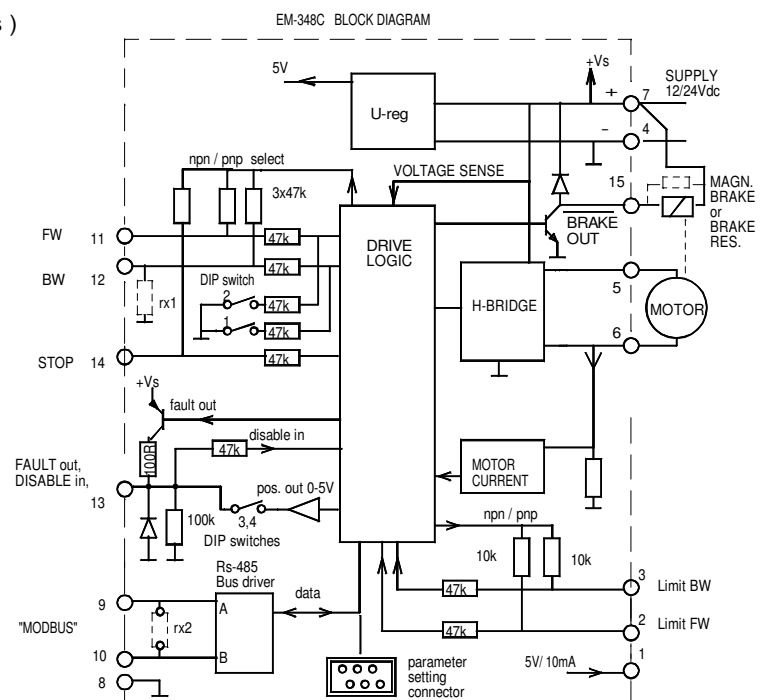

"rx" resistors are optional for special applications



CONNECTIONS

Supply voltage must be filtered DC of 10-35V, and ripple should be less than 30% at full load.
CAUTION ! Wrong polarity can damage the unit.
CAUTION ! Unit doesn't have an internal fuse, so an external fuse should be added if fuse required.

FAULT-LED signal codes

- | | |
|---------------------|------------------------------|
| 1. power on | one blink |
| 2. current on limit | led is lit |
| 3. current trip | fast blinking... |
| 4. zero-cur trip | long blink- short pause... |
| 5. overvoltage | 4 x blink -pause... |
| 6. overheat | short blink- long pause... |
| 7. timeout | 3 x blink + long blink... |
| 8. fault input | 2 x short + 1x long blink... |

FW and BW inputs for start of motor

STOP input stop motor, but new FW / BW command can restart motor although STOP occurs

FW -limit and BW-limit (end limit inputs)
 These inputs stop motor without ramp with dynamic brake
 But in control mode "2-speed" dynamic brake is enabled only when speed-2 is activated.
 If motor has stopped with limit switch the dynamic brake is at least 1s. active, also in case when freewheel is selected.

FAULT in/out
 This PNP input pulls up when fault. Combination can be selected with parameter 10.
 If this input is pulled up with externally, then it would disabled motor as long as pulled up.

BRAKE OUT
 This is nominally 2A NPN output This output could use to control brake resistor or magnetic brake.
 This can be set set with parameter 21

Rs-485 PORT (Modbus RTU)
 This is two wire bus for open protol control (Modbus)
 This option has own instruction guide.

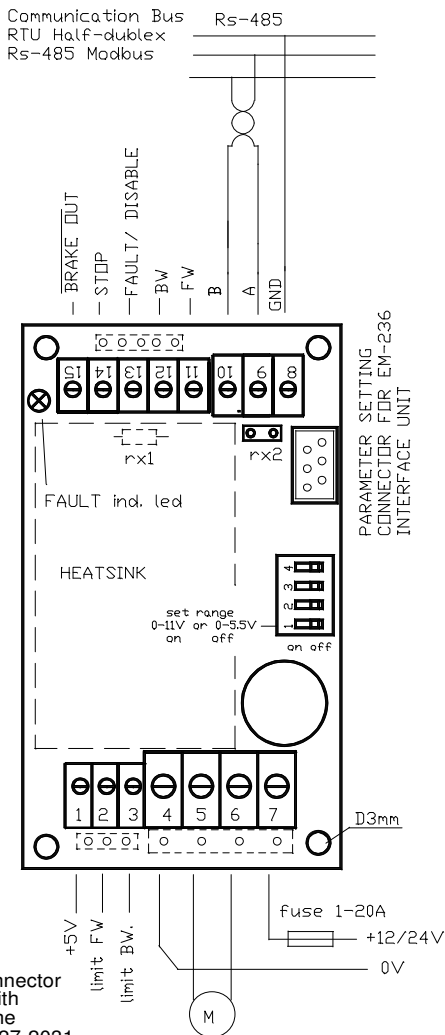

Molex connector options with dashed line
 3-pin 22-27-2031
 4-pin 10-08-5041
 5-pin 22-27-2051

SETTINGS and MONITORING (prog ver. EM-348C V1.9)

Settings can be done with three interface device options:
 1. EM-236 interface unit
 2. EM-268 interface unit with EmenTool Lite PC-software
 3. EM-326 interface unit with EmenTool App smartphone application
 When using App you can set device-specific access code, which protects device against unauthorized smartphone connections. The access code can be reset with simultaneous FW and BW comand, when power switch on.

SETTABLE PARAMETERS prog. 348C v1.9 (def. in brackets)

- 1 command mode: (0)
 continuous = 0,
 impulse = 1 direction change with stop
 impulse 2 = 2 dir. change without stop
- 2 start condition combinations: 0-3 (1)
 0= start both direction after I-trip and Stop
 1= start only opposite direction after I-trip
 2= start only opposite direction after Stop
 3= start only opposite direction after I- and Stop
- 3 input logic combinations 0-7 PNP/NPN (0)
 PNP control with positive signal and input has pull down res.
 NPN control with negative signal and input has pull up res.
 N.C. = input resistor as above, but action signal logic is inverted
 Control inputs are pin 11,12 and 14 / limit inputs are pin 2 and 3
 0= cont. PNP, limits PNP 4=cont. PNP, limits PNP N.C.
 1= cont. NPN, limits PNP 5=cont. NPN, limits PNP N.C.
 2= cont. PNP, limits NPN N.C. 6=cont. PNP, limits NPN
 3= cont. NPN, limits NPN N.C. 7=cont. NPN, limits NPN
- 4 running speed-1: 0-100% / 0-100 (100)
 If analog speed input mode is select with parameter 5,
 then parameter 4 work analog input range adjust
- 5 not in use
- 6 current limit FW: 0.1-25A / 1-250 (30)
- 7 current limit REV: 0.1-25A / 1-250 (30)
- 8 Trip combinations: 0-3 (1)
 0= no I-trip, no zero-current-trip
 1= only I-trip
 2= only zero-current-trip
 3= both I-trip and zero-current-trip
- 9 I-trip delay: 0-255ms / 0-255 (20)
- 10 Fault output combinations: 0-5 (1)
 0= I-trip and zero current won't cause fault output signal
 1= only I-trip causes fault output signal
 2= only zero current causes fault output signal
 3= both I-trip and zero current causes fault output signal.
 4= overcurrent indication = pull down
 5= "run" indication = pull down when motor run
- 11 overvoltage limit: 15-65V / 15-65 (35)
 Do not set higher than 40 - hardware limitation
 Overvoltage can be caused when motor slowing down or when external force rotating motor, then the voltage rises result of regenerating energy. Exceeding the limit will cause first the powerstage releasing to freewheel, and next the limit+3V the power stage starts dynamic braking.
- 12 load compensation: 0-255 / 0-255 (0)
 Load compensation (Rxl) improves low speed and start torque, but too high compensation achieve unstable running. Run motor at low speed (30%) Increase compensation with small steps until motor start behaviour unstable, then decrease value about 10%
- 13 timeout: 0-255s. / 0-255 (0=not in use) (0)
- 14 reset for start and hour-counter 0/1 (0)
 selecting 1 and push save = reset counters
- 15 start ramp: 0-5s / 0-500 (100)
- 16 stop ramp: 0-5s / 0-500 (100)
- 17 start kick 0-200ms / 0-200 (0)
 gives short 0-200ms full drive pulse for start
- 18- I-trip auto reversing 0-5s / 0-500 (0)
 Change automatically run direction when I-trip occurs
 the reversing time will select with this parameter
- 19- Freewheel options 0-3 (0)
 0= freewheeling when overvoltage
 1= freewheeling when overv. or stopped
 2= freewheeling when overv. or during stop ramp
 3= freewheeling when overv. or when stopped or during stop ramp
- 20- Pwm frequency 1=2kHz / 2=16kHz (1)
- 21- Brake out mode (pin 15) 0-2
 0= overvoltage activates = brake resistor control
 1= run indication = active when motor run
 2= as above but also the Stop in activates brake out
- 22 Serial port configuration, speed, parity, and number of stop bits (1)
 1 =9600bps 8N1 5 =19200bps 8N1
 2 =9600bps 8N2 6 =19200bps 8N2
 3 =9600bps 8E1 7 =19200bps 8E1
 4 =9600bps 8O1 8 =19200bps 8O1
- 23 Modbus address 1-247 (1)

MONITORABLE VALUES

- 1 Motor current 0-2.0A (0-200)
- 2 PWM-level-% 0-100% (0-100)
- 3 hour counter (max.65535h)
- 4 start counter (max.65535)
- 5 carry counter for start counter